

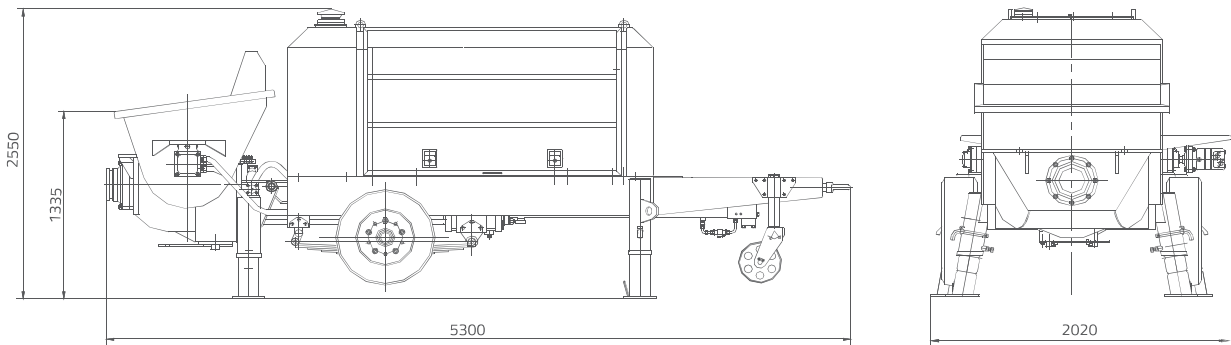

HBT50.10.60RS



HBT50.10.60RS



Pumping performance diagram

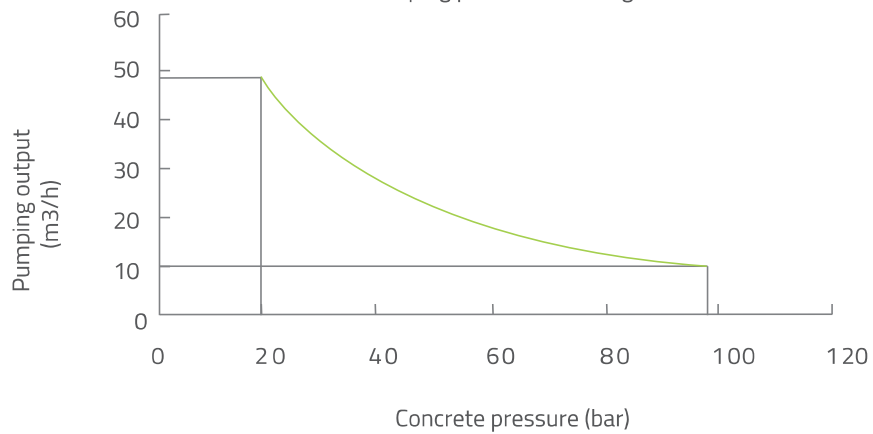



HBT50.10.60RS

Main Features

- **Intelligent control system:** Self diagnosis and protection function make the machine more stable and reliable. Configuration of the touch screen, real-time monitoring of operating conditions, view the fault records and maintenance skills.
- **Dual pump dual circuit hydraulic system:** Pumping hydraulic system and distribution hydraulic system cooperate with each other and do not interfere with each other. This design is easy to realize the logic control, and make the best performance of hydraulic system.
- **Flexible reversing technique:** Monitoring the whole pumping conditions. Automatically adjust the various mechanism to achieve smooth pumping of concrete without impact, improve the pumping efficiency, and extend parts' lives.
- **Best time difference logic reversing technique:** The main cylinder reversing and S valve change-over time is in the best state. The reversing impact is small, and the components' lives are longer.
- **Engine start at a key:** According to the rotation speed and the starting time, the utility model can automatically close or cut off the starting circuit. Protect the starting motor of the diesel engine.
- **Adaptive variable power technology:** According to the concrete conditions and pumping conditions, engine can always work at the best load rate, to ensure that it works at the economic fuel consumption level.
- **Long life wearing parts:** Reduce working cost remarkably. Continuously improve wearing part' s life by using material, new process and new designing.

Standard Equipment

- 4 outriggers.
- Drawbar.
- Taper pipe.
- High/low pressure shifting.
- Air-cooling device.
- PLC.

Optional

- Electric vibrator on grid
- Water pump.

Technical Data

Model		HBT50.10.60RS
Max. theoretical output	m ³ /h	49/26
Max. theoretical concrete output pressure	bar	50/100
Strokes/minute	Min ⁻¹	26/13.8
Concrete cylinder (diameter x stroke)	mm	Φ180×1250
Hopper capacity	L	500
Filling height	mm	1335
Max. aggregate diameter/ Inside diameter of delivering pipe	mm	50/Φ150 40/Φ125
Inside diameter of pipe	mm	Φ125/Φ150
Hydraulic system type		Open
Power	kW	60
Length x width x height	mm	5300×2020×2550
Weight	kg	4500

Technical data and characteristic subject to modifications without notice.



L&W EQUIPMENT
GROUP LIMITED

Phone: 021 273 7369
E-mail: info@lw-equipment.com

Add: 781 Te Atatu Road, Peninsula, Auckland, 0610
Web: lw-equipment.com